

HONDA

INSTALLATION INSTRUCTIONS

Accessory
**TOP BOX
(WAVE KEY TYPE)**
P/N 08L71-MJP-G50

Application
CRF1100A/A2/A4/D/D2/D4

Publication No.
MII
Issue Date
June 2021

Honda Dealer: Please give a copy of these instructions to your customer.

PARTS LIST

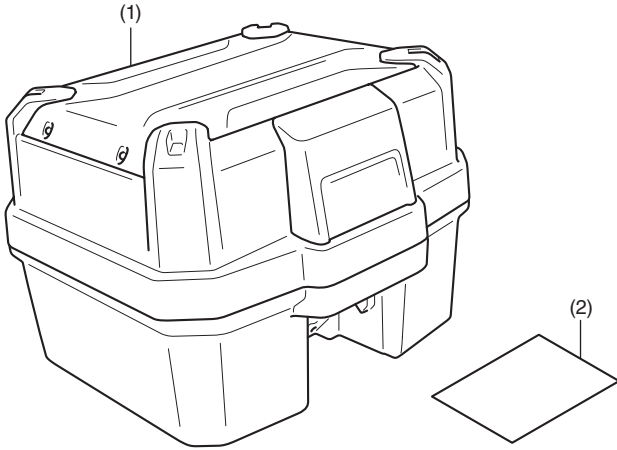

No.	Description	Qty
(1)	Top box	1
(2)	URL paper	1

TOP BOX LOCK Sold separately

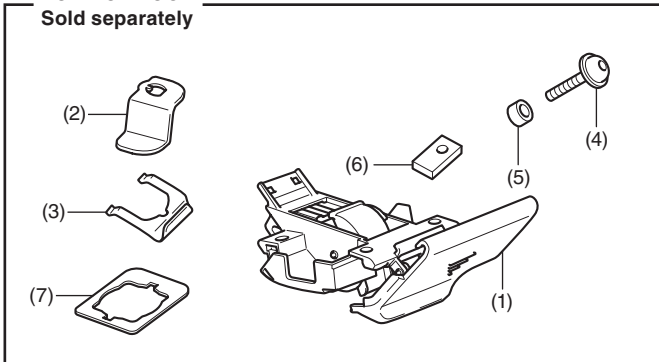

No.	Description	Qty
(1)	Lock assembly	1
(2)	Cam plate	1
(3)	Key lock spring	1
(4)	6 mm socket bolt	4
(5)	Collar	4
(6)	6 mm square nut	4
(7)	Key lock washer	1

CARRIER BRACKET Sold separately

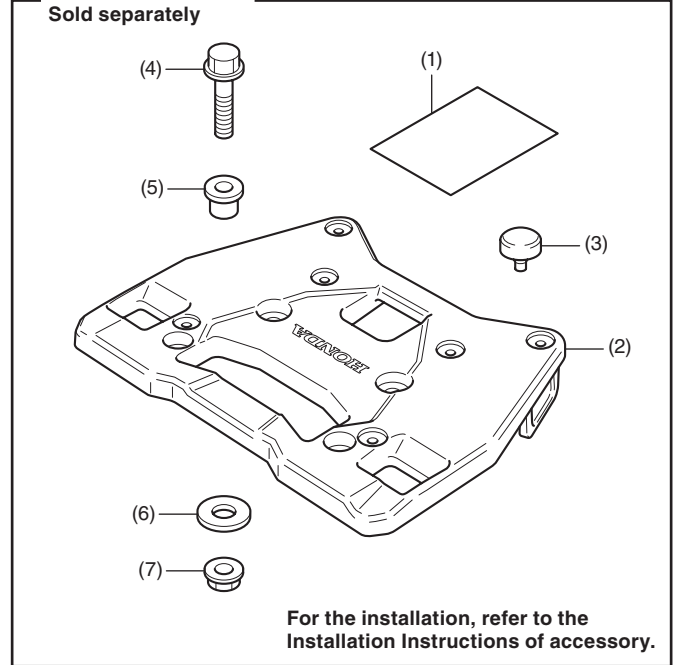

No.	Description	Qty
(1)	URL paper	1
(2)	Carrier base	1
(3)	Rubber	6
(4)	8 mm flange bolt	4
(5)	Flange collar	4
(6)	Washer	4
(7)	8 mm flange nut	4

1 KEY BODY PARTS Sold separately

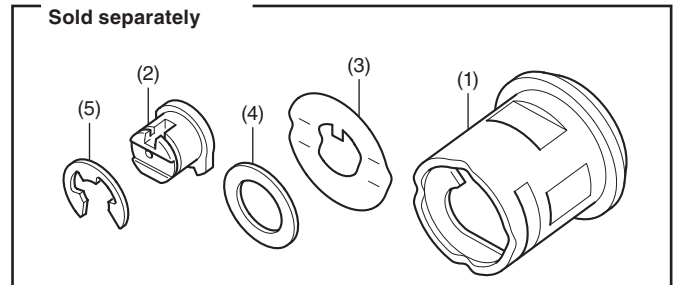

No.	Description	Qty
(1)	Cylinder body	1
(2)	Inner joint	1
(3)	Spring plate	1
(4)	Washer	1
(5)	E-ring	1

1 KEY INNER CYLINDER (Wave key type)

Sold separately

- Do not use the [] slots.

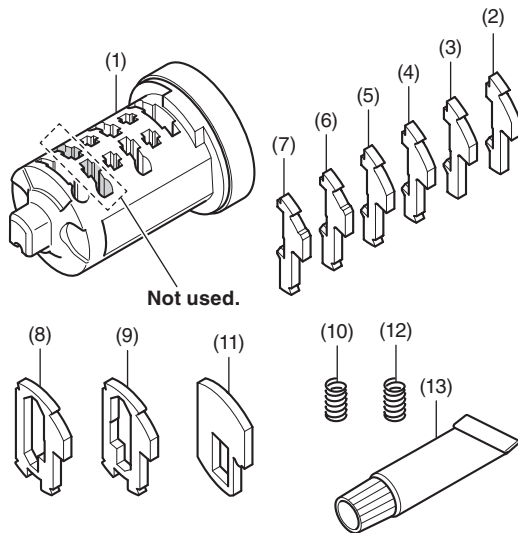

No.	Description	Qty
(1)	Inner cylinder	1
(2)	No.1 tumbler	6
(3)	No.2 tumbler	6
(4)	No.3 tumbler	6
(5)	No.4 tumbler	6
(6)	No.5 tumbler	6
(7)	No.6 tumbler	6
(8)	Sub-lock tumbler A	1
(9)	Sub-lock tumbler B	1
(10)	Spring (Silver)	13
(11)	Stopper tumbler	2
(12)	Stopper spring (Black)	2
(13)	Grease	1

TOOLS AND SUPPLY REQUIRED

- Hex wrench (4 mm)
- Long nose pliers
- Torque wrench

MAXIMUM LOADING CAPACITY

- The weight of the cargo must not exceed the following maximum loading capacity:

Maximum Loading Capacity	
Top box	6.0 kg (13.2 lb)

TORQUE CHART

Tighten all screws, bolts, and nuts to their specified torque values. Refer to the Service Manual for the torque values of the removed parts.

Item	N·m	kgf·m	lbf·ft
6 mm socket bolt	10	1.0	7

< Notes regarding the key cylinder >

- This product is used to assemble a key cylinder matching the motorcycle key by combining six types of tumblers.
- When this key cylinder is installed in a box or similar equipment, the installed equipment can be operated with the motorcycle key.

Combine six types of tumblers.

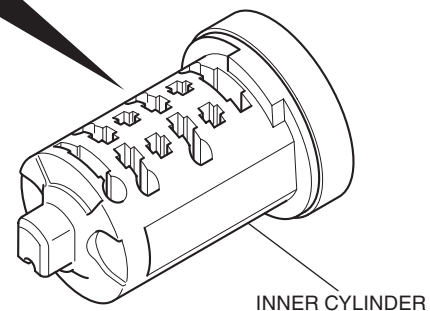
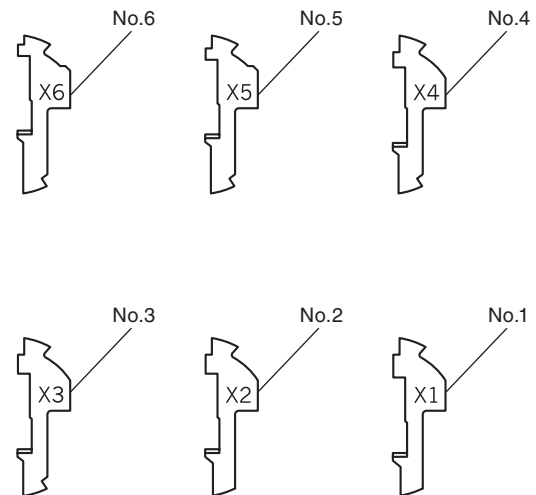

INSTALLATION

1. The two sub-lock tumbler types shown are provided.
 - The  part has a different slot for each of the two sub-lock tumbler types.
 - As the tumblers are small, keep them in the bag until they are used.

SUB-LOCK TUMBLER A

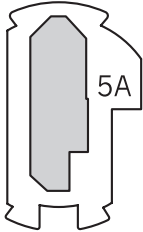

SUB-LOCK TUMBLER B

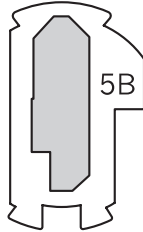

The stopper tumbler will be used later.

STOPPER TUMBLER



2. The six tumbler types shown are provided.
 - The  part has a different width for each of the six tumbler types.
 - As the tumblers are small, keep them in the bag until they are used.

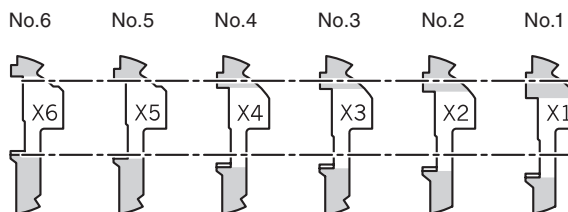

3. Install the tumblers and springs (silver) as shown.
- **First install four No.1 tumblers.**
 - **Note the installed tumbler to below chart.**

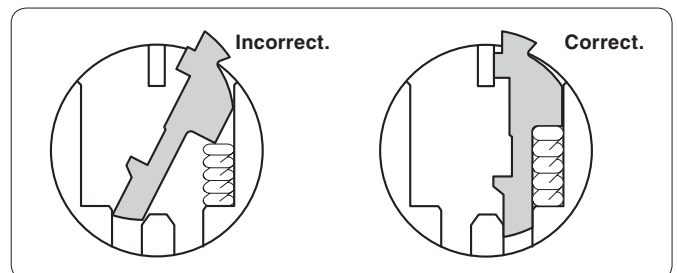
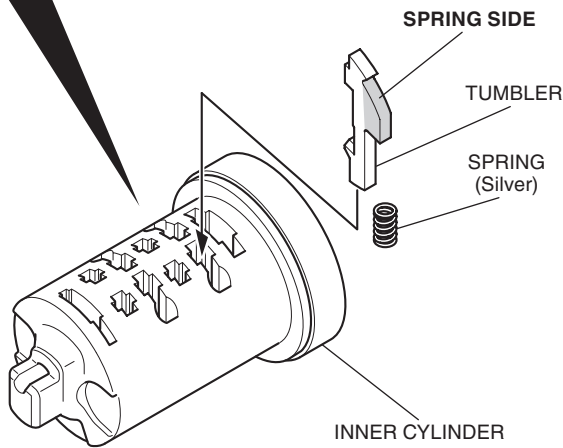
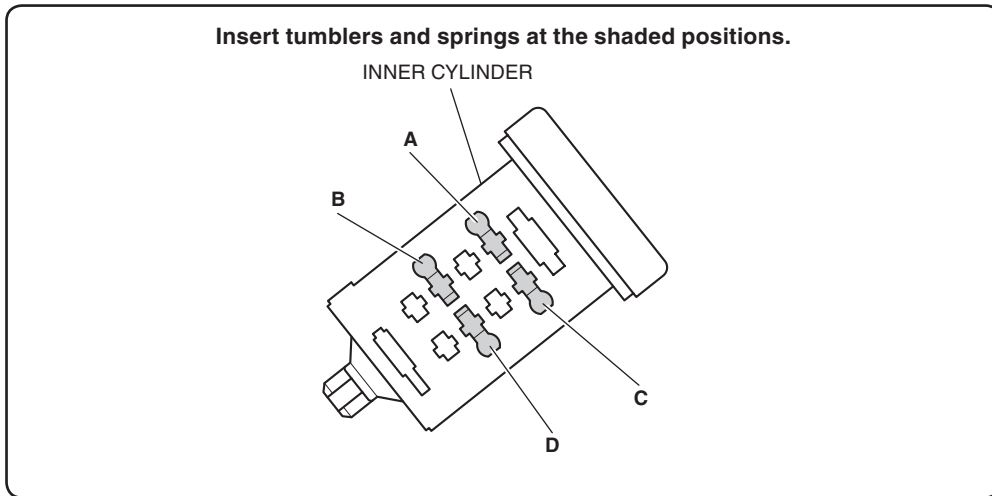

	Position A	Position B	Position C	Position D
No.1 tumbler				
No.2 tumbler				
No.3 tumbler				
No.4 tumbler				
No.5 tumbler				
No.6 tumbler				

4. Insert the key as shown.
 - **Lightly press down on the tumblers from above, then insert the key.**

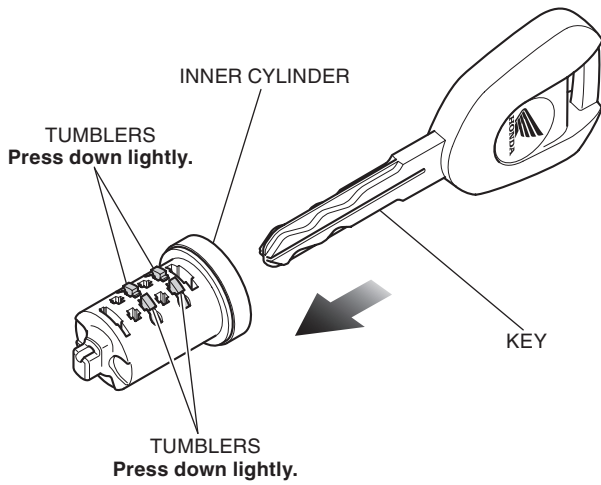

5. Confirm that some tumblers are projecting. Mark the positions of the projected tumblers.
 - **The positions where tumblers project and the projecting height differ according to the key.**

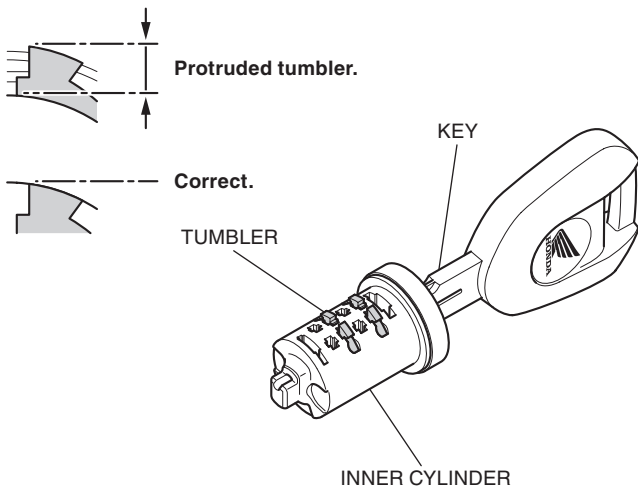

6. Press down lightly on the tumbler, pull the key out.
 - **The tumbler spring may jump out when the tumbler is not pressed down lightly.**

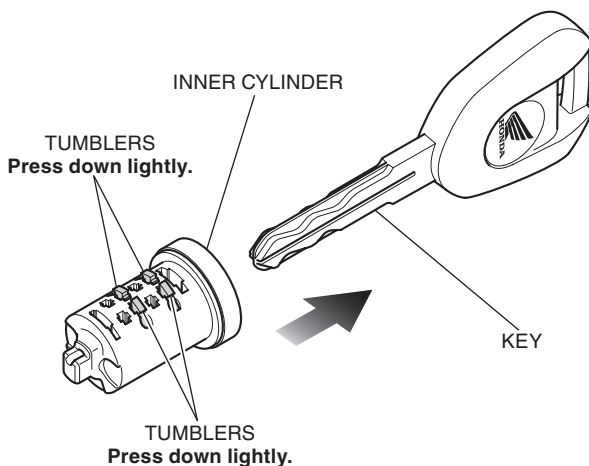

7. Pull out the projecting tumbler(s).
 - **Leave the spring(s) installed.**

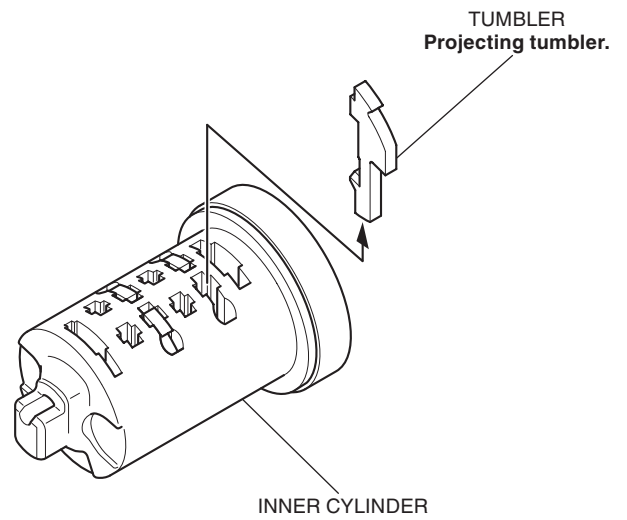

8. Insert a different tumbler(s) at the marked positions.
 - **Use a tumbler of next number one stage.**

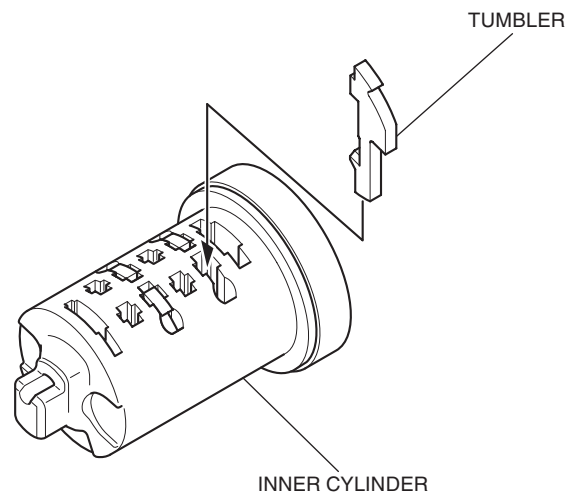

9. Repeat steps 4 to 8, inserting different tumblers at the marked positions until no tumblers are projected.
 - **Lightly press down on the tumblers from above, then insert the key.**

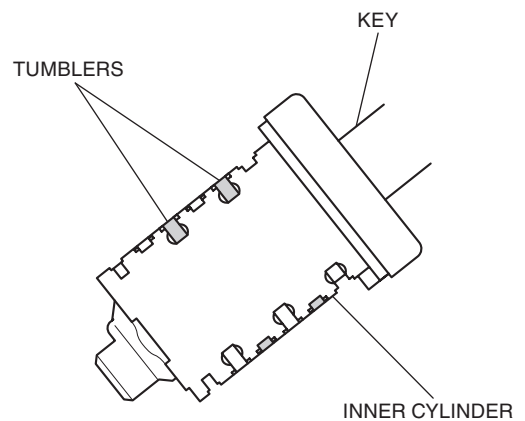

10. Install the tumblers and springs (silver) to the reverse side inner cylinder as shown.

- **First install two No.1 tumblers.**

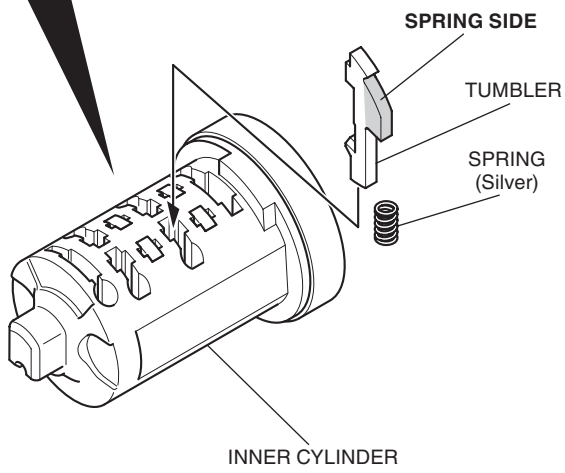
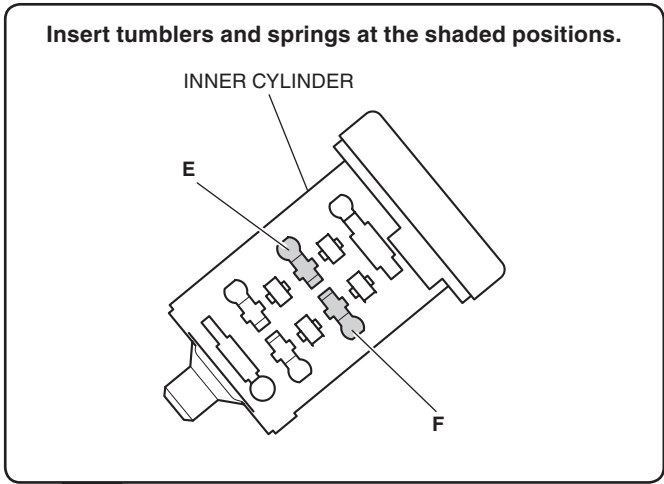

- **Note the installed tumbler to below chart.**

	Position E	Position F
No.1 tumbler		
No.2 tumbler		
No.3 tumbler		
No.4 tumbler		
No.5 tumbler		
No.6 tumbler		

11. Use steps 8 through 8 to assemble the reverse side inner cylinder in the same manner.

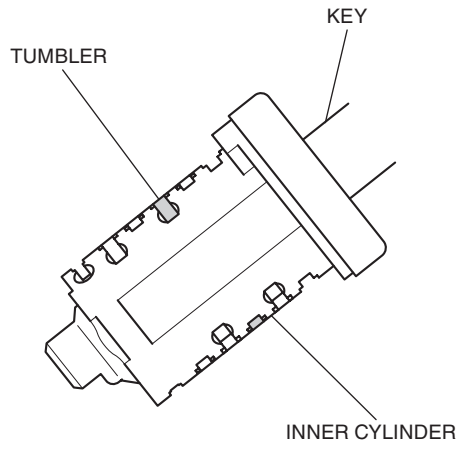

12. Install the sub-lock tumbler as shown.

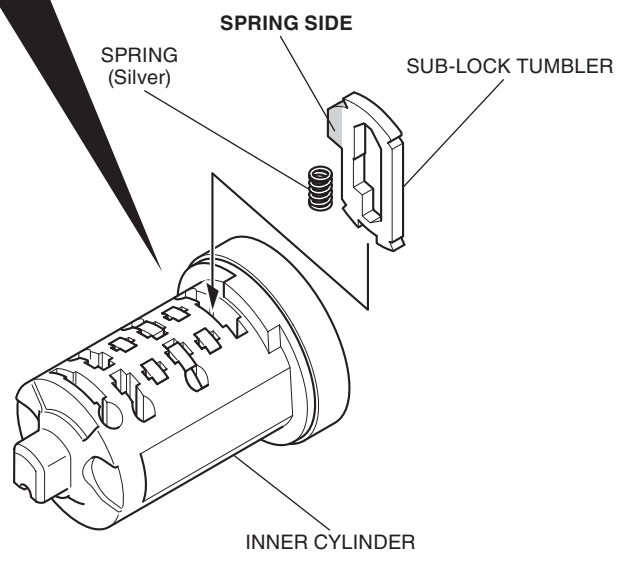
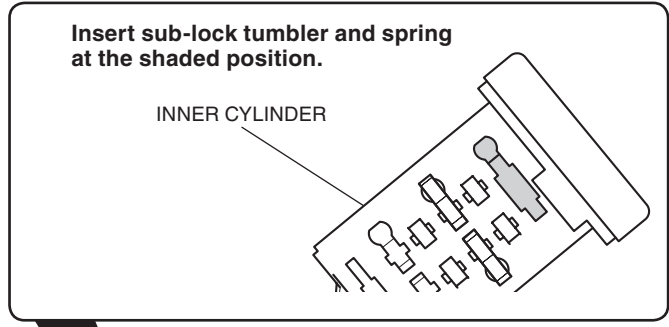

- **Note the installed tumbler to below chart.**

Sub-lock tumbler A	
Sub-lock tumbler B	

13. Confirm that sub-lock tumbler is not projecting.
- **If the tumbler is projected, change the another sub-lock tumbler and recheck.**

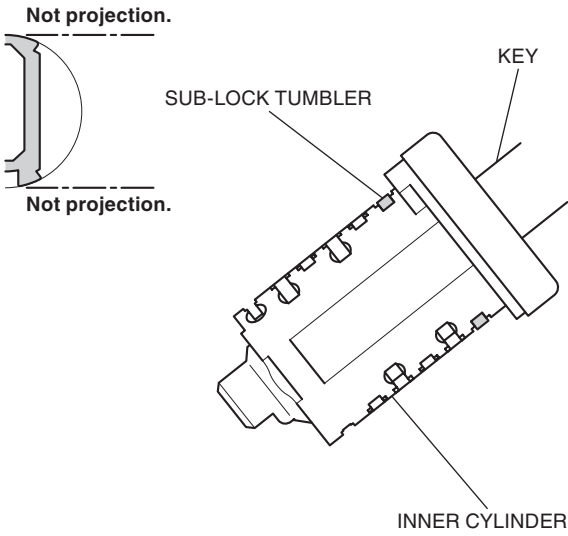

14. Insert the assembled inner cylinder into the cylinder body as shown.
- **Confirm the inner cylinder turns clockwise smoothly.**

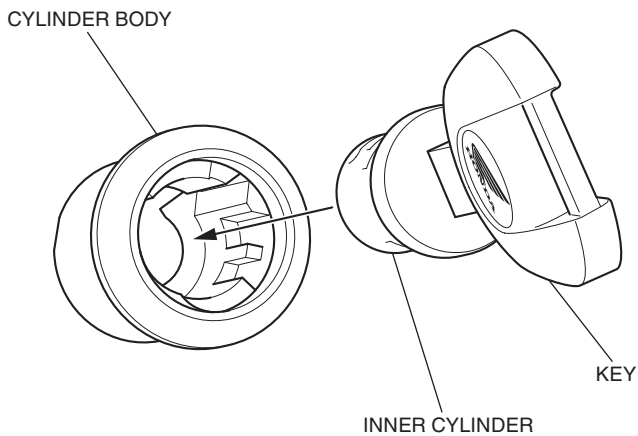

15. Pull out the inner cylinder.
16. Press down lightly on the tumblers and pull out the key.

17. Install the stopper tumbler and stopper spring (black) as shown.

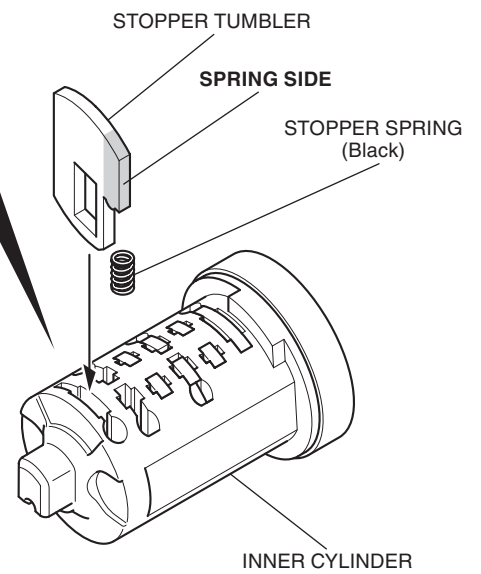
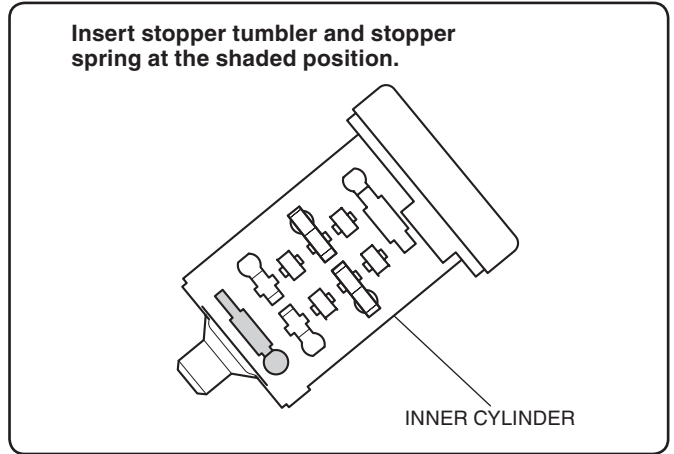

18. Insert the key as shown.
- **Lightly press down on the tumblers from above, then insert the key.**
 - **Confirm that the stopper tumbler jumps out.**

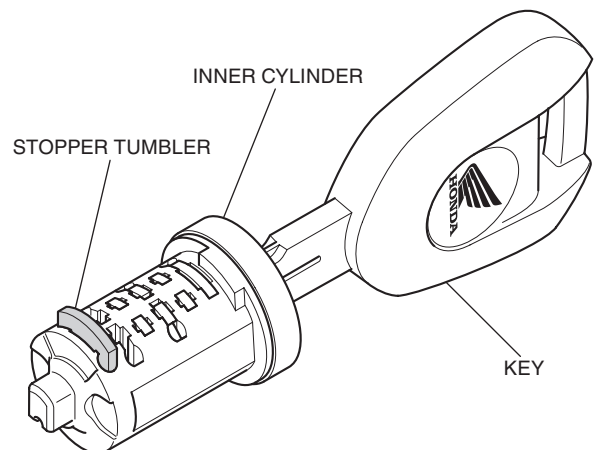

19. Apply grease to the shaded areas as shown.
- Apply to the inner joint, tumbler and to the outer circumference of the inner cylinder.
 - Only use the supplied grease.

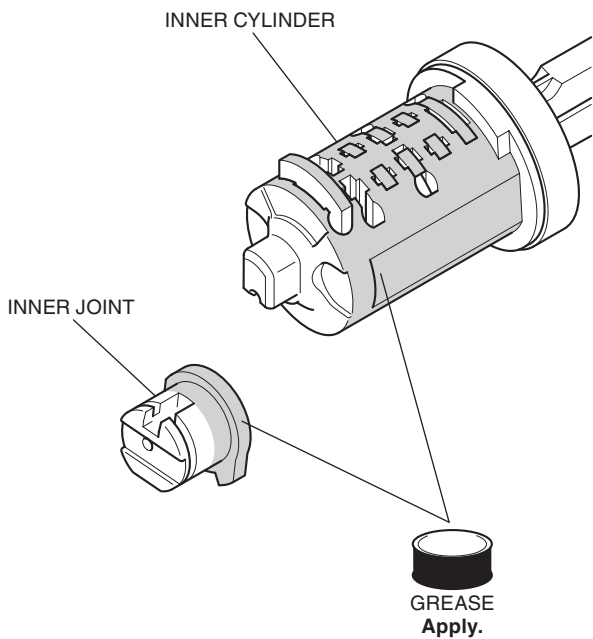

20. Install the inner joint into the cylinder body as shown.

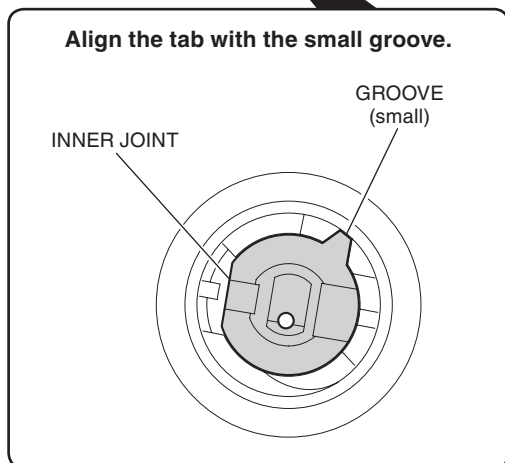
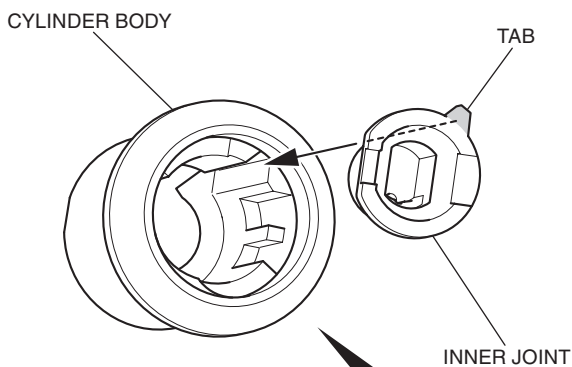

21. Install the inner cylinder by sliding the stopper tumbler along the slide guide while rotating it.
- If the inner cylinder cannot be inserted, again confirm that no tumblers other than the stopper tumbler have jumped out.

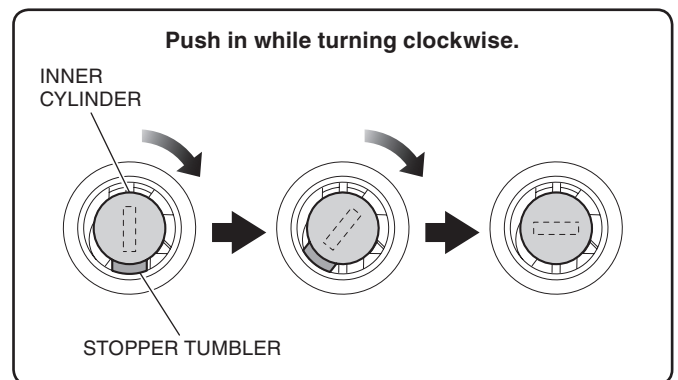
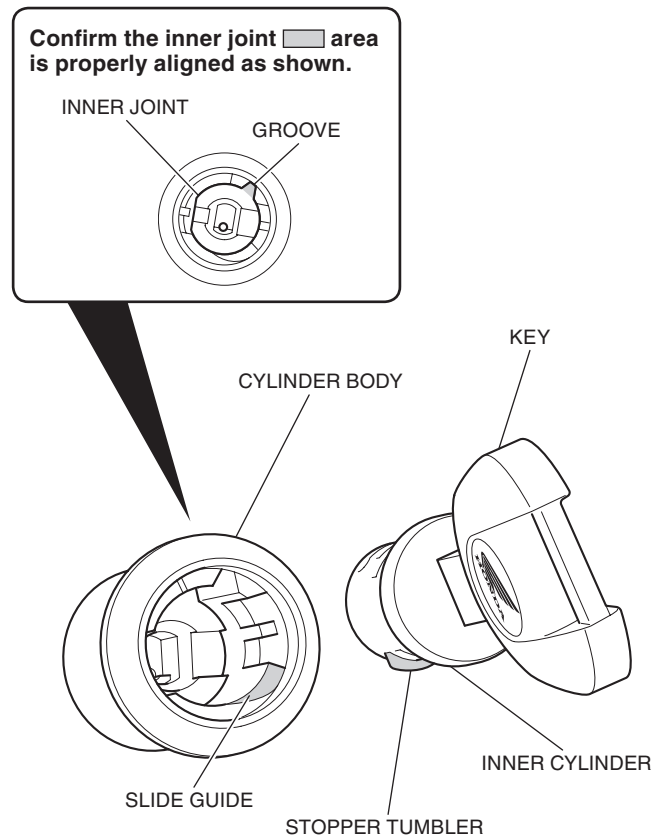

22. Draw out the key and check that the inner cylinder does not come out.

23. Insert the key and attach the assembled cylinder body to the lock assembly as shown.

- Only use the supplied grease.

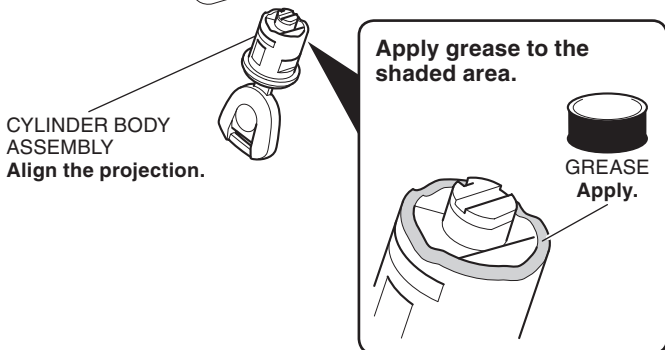
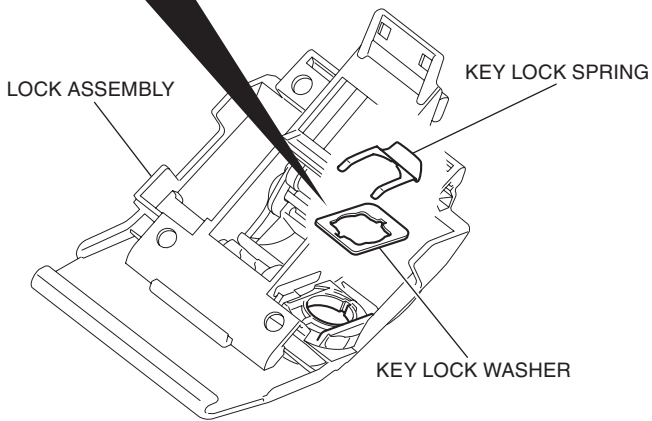
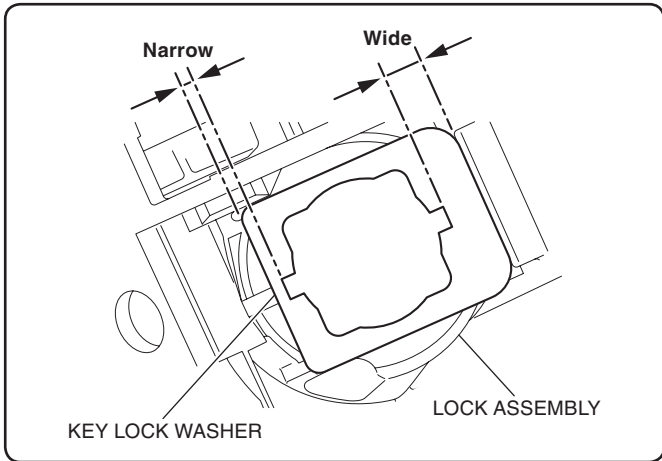

Install the key lock spring while aligning the projection on the cylinder body assembly with the cutout in the lock assembly as shown.

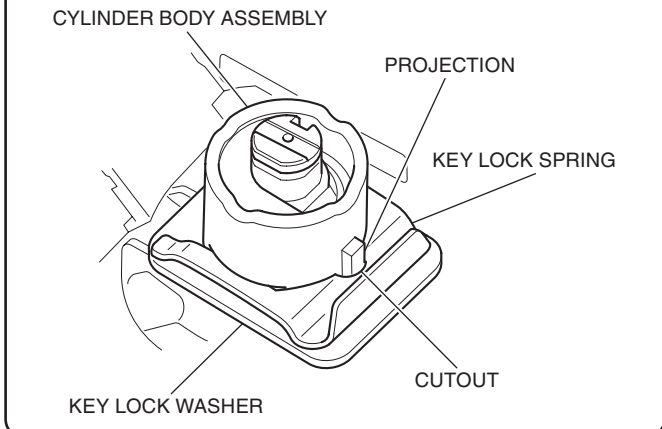

24. Install the spring plate as shown.

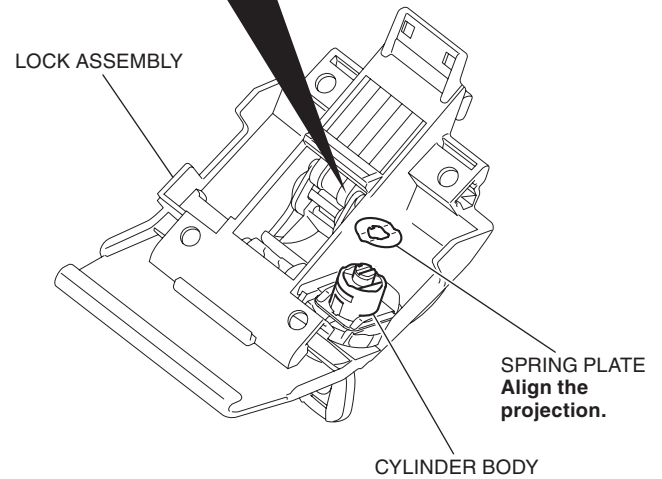
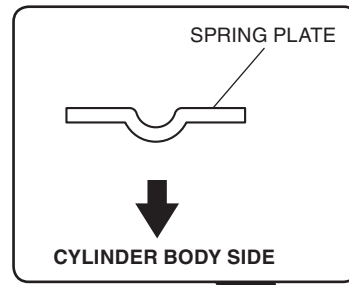

25. Install the cam plate, washer and e-ring as shown.

- Align the projection on the cam plate with the cutout in the inner joint.

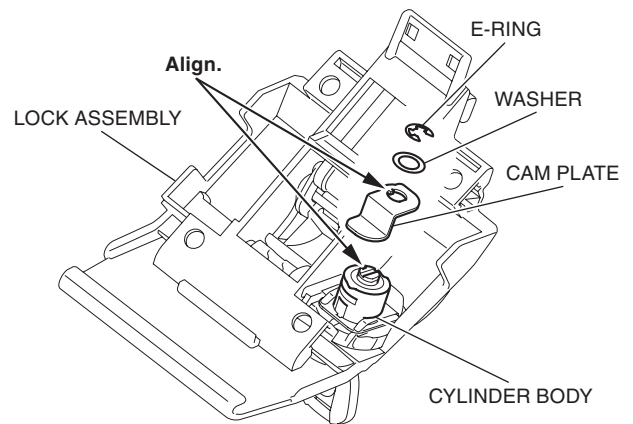

26. Turn the key and check the key lock system as shown.

- If the key lock system is not operation, reassemble the cylinder body.

<LOCK>

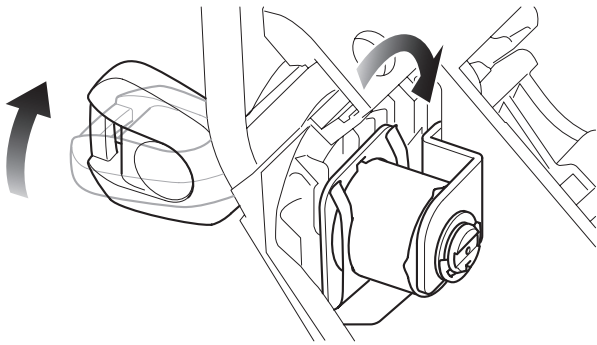

<UNLOCK>

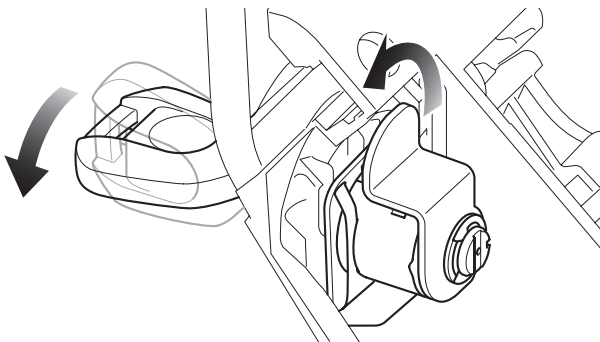

27. Install the 6 mm square nuts as shown.

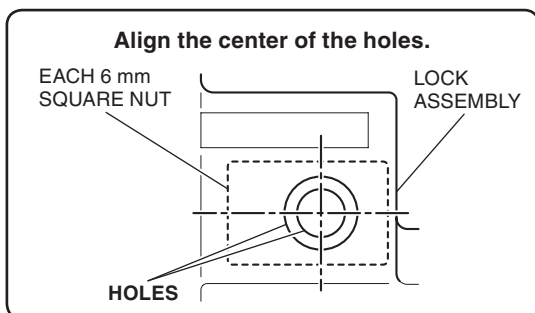
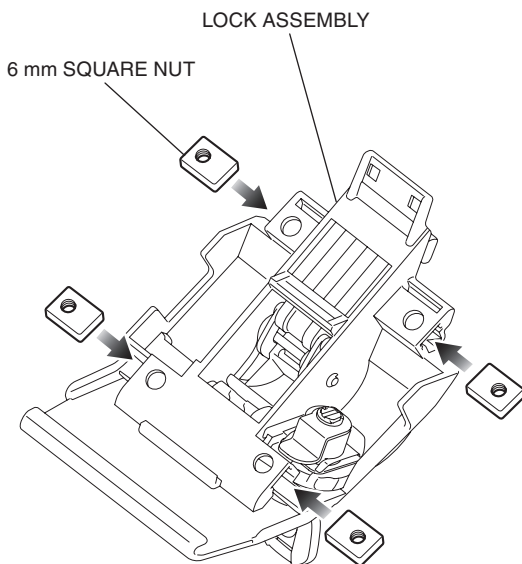

28. Lower the lever and turn the key counter-clockwise as shown.

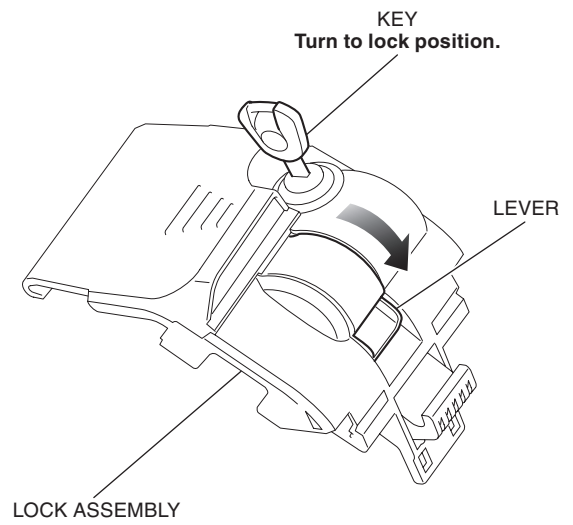

29. Open the lid.

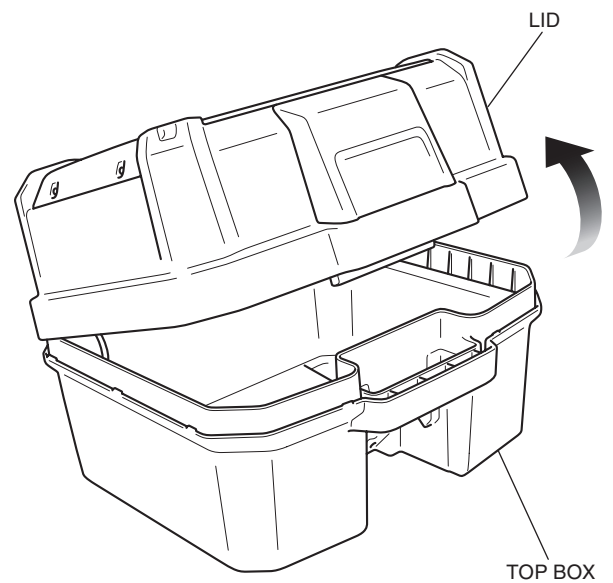

30. Install the lock assembly lightly into the top box as shown.

Hook the lock assembly on the rib of the top box as shown.

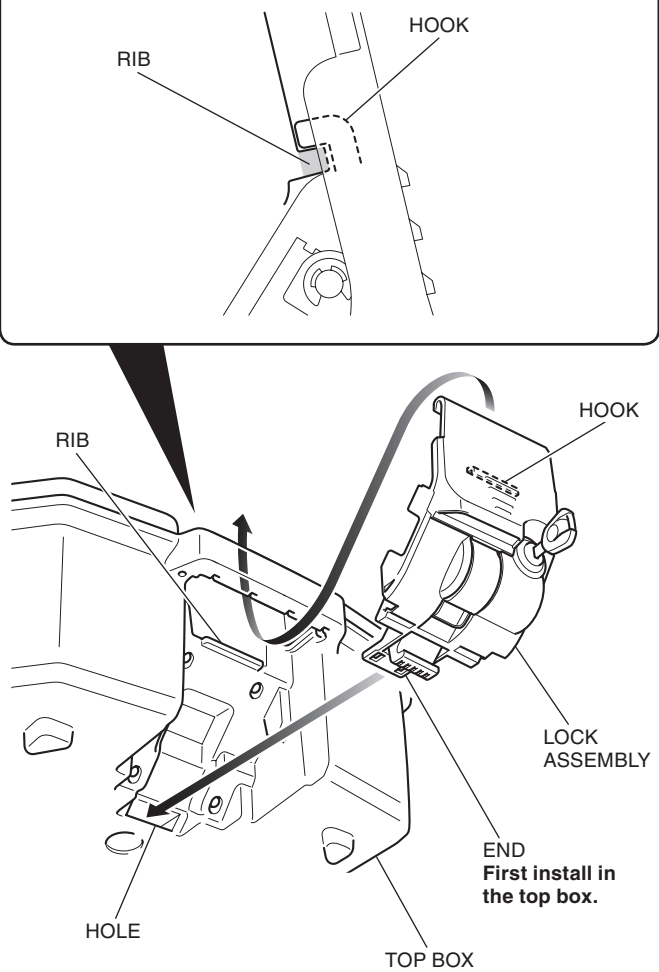

31. Secure the lock assembly as shown.

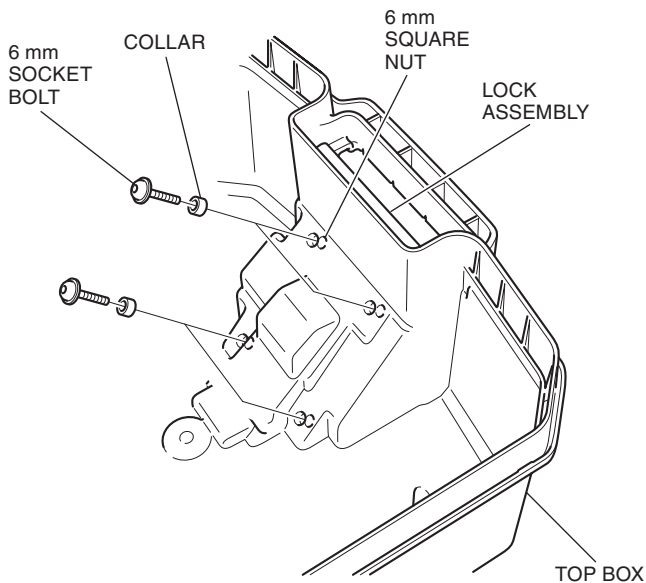

FOR USE OF THE TOP BOX

⚠ CAUTION

- To prevent burns, allow the engine, exhaust system, radiator, etc., to cool before installing and removing the accessory.

How to Open the Top box

1. Insert the key and release the lock by turning the key clockwise.

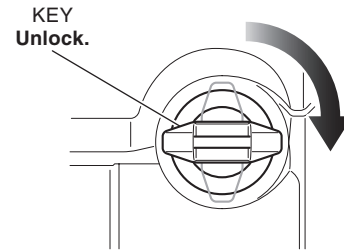

2. Pull the hinge up as shown.

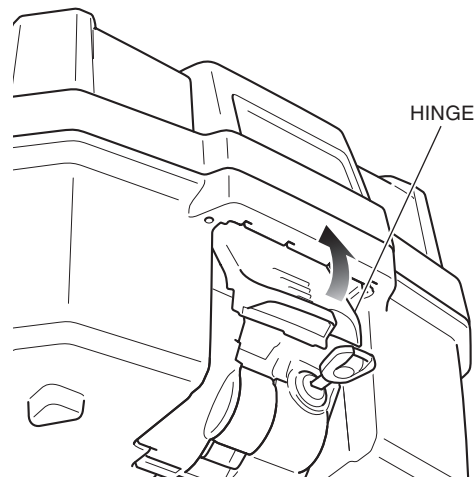

3. Raising the upper part of hinge, move the hinge down as shown and open the lid.

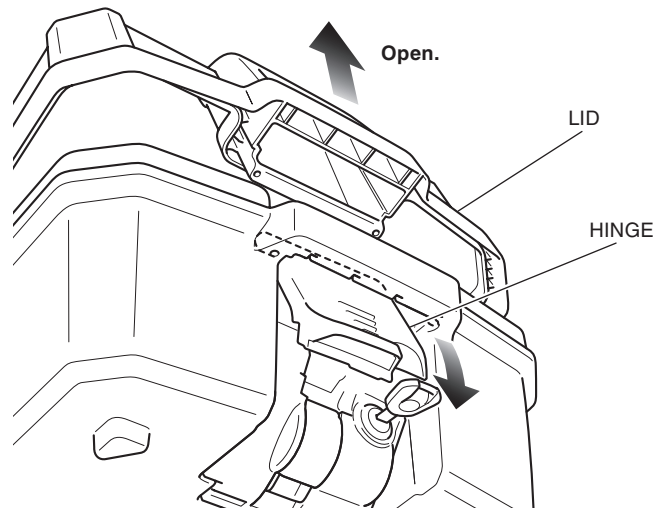

How to Close the Top box

1. Confirm that the key position is as shown.

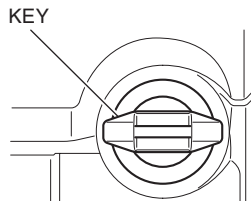

2. Close the lid.

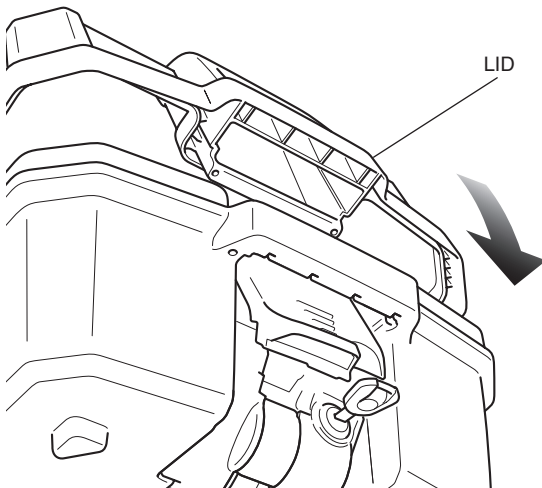

3. Holding the upper part of the hinge, push the hinge down.

- **Be careful not to have the stored item pinched when the top box is closed.**

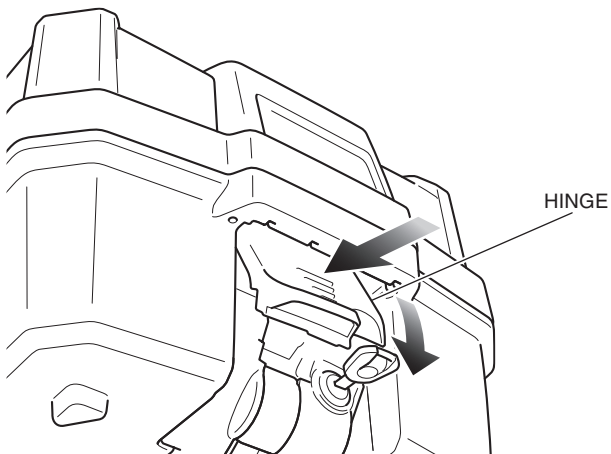

4. Lock the top box by turn the key counter-clockwise as shown.

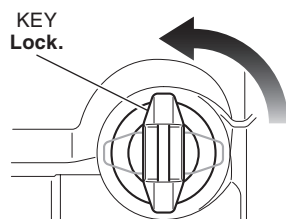

5. Remove the key.
 - **Make sure the lid and hinge are locked down securely.**

How to Install the Top box

1. Install the carrier bracket (sold separately).
2. Insert the key and release the lock by turning the key clockwise.

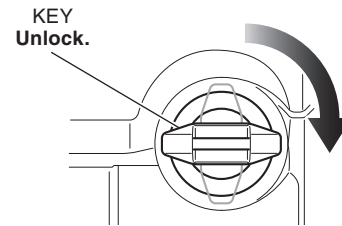

3. Lift the lever as shown, and insert the retaining tab of the top box into the hole of the carrier base.

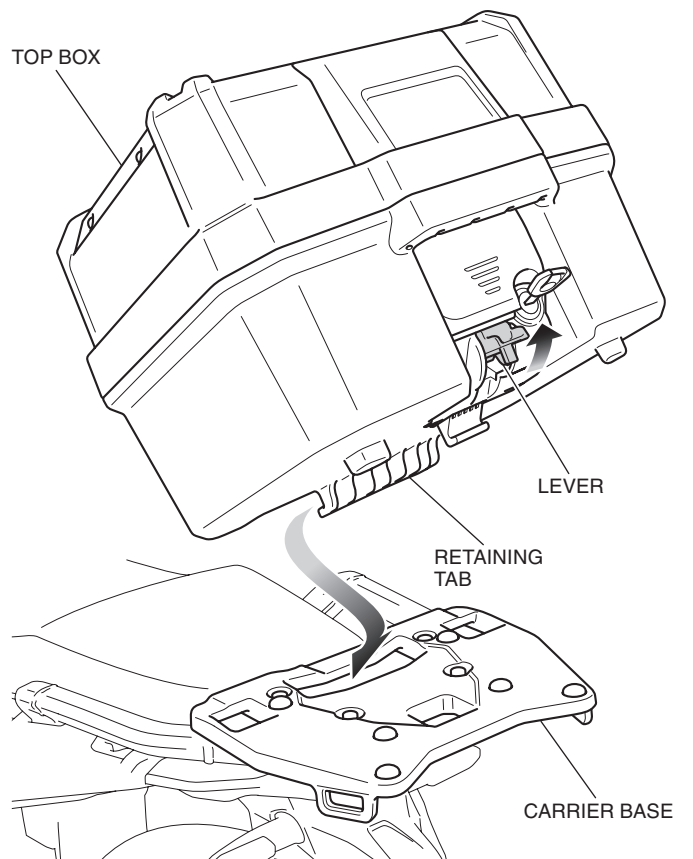

4. Position the hook of the lock assembly on the carrier base as shown.

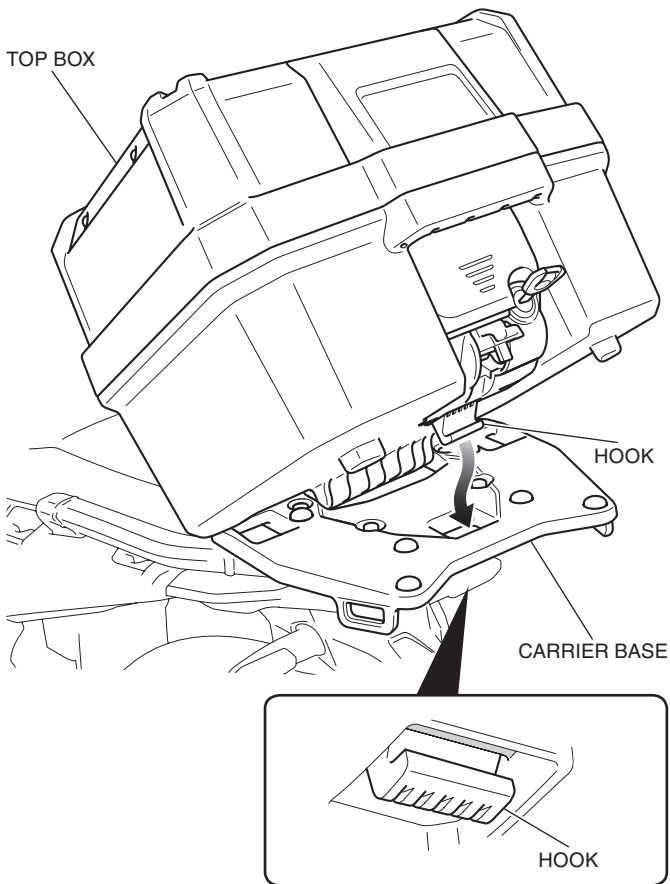

5. Secure the hook by pressing the lever down as shown.

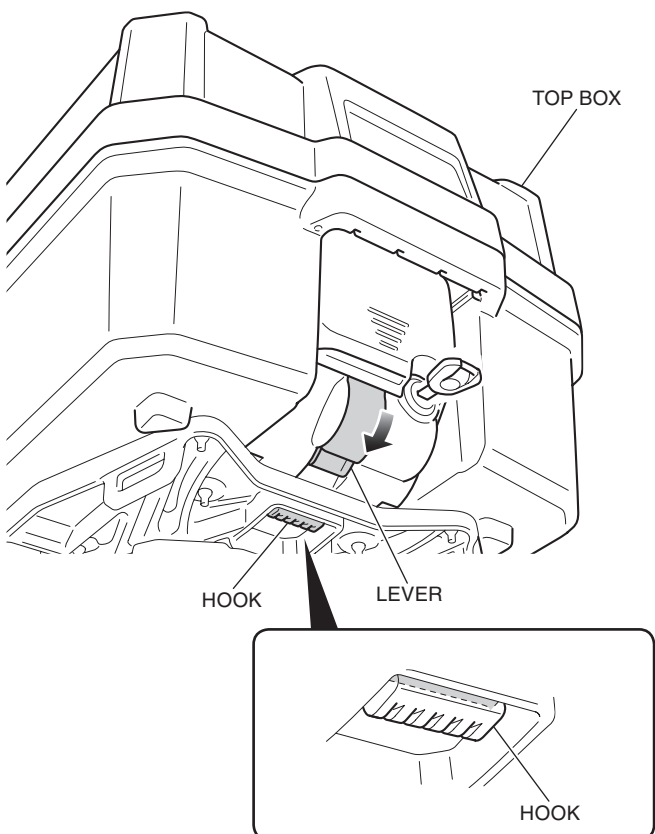

6. Lock the top box by turning the key counter-clockwise as shown.

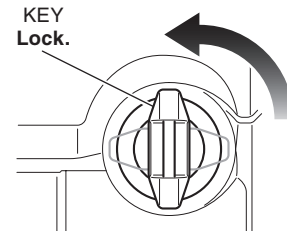

7. Remove the key. Be sure that lever cannot be released.

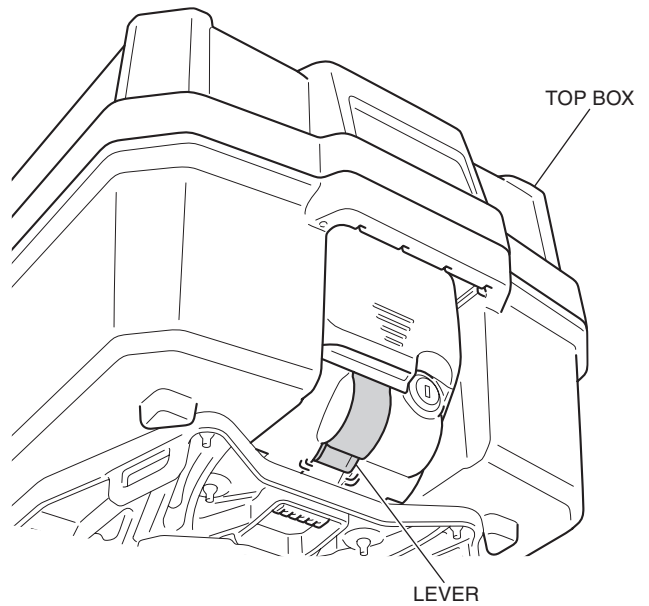

8. Check that the top box is installed securely by swinging the top box taking care not to fall the motorcycle down.

- **The top box can come off during riding unless it is mounted securely.**

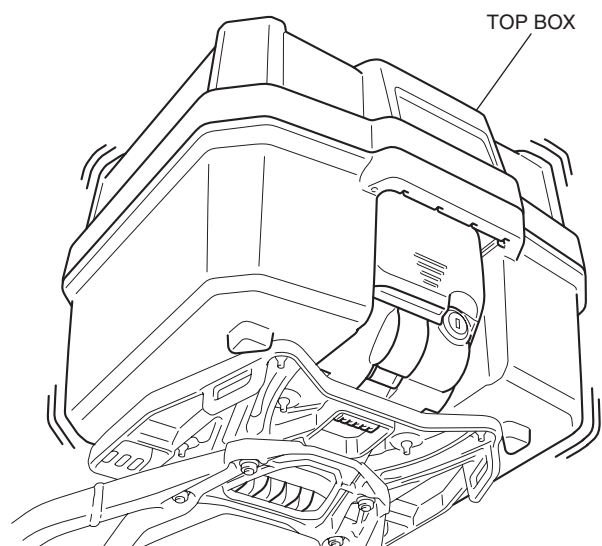

How to Remove the Top box

1. Remove the top box in the reverse order of installation.

How to Store the Top box inner bag

1. Open the top box and store the top box inner bag.
2. Close the top box.
 - **Be careful not to have the stored item pinched when the top box is closed.**